



ISOMETRIC VIEW  
SCALE 2:3

FC/PC CONNECTOR W/ KNURLED LOCKING NUT  
SPRING LOADED STAINLESS STEEL FERRULE  
2.0mm NARROW KEY

FERRULE BORE DIAMETER:  
 $\text{Ø}260\mu\text{m} +10/-0\mu\text{m}$

CRIMP SLEEVE

STRAIN RELIEF BOOT  
USED WITH 3.0mm FURCATION TUBING

EXPLODED VIEW

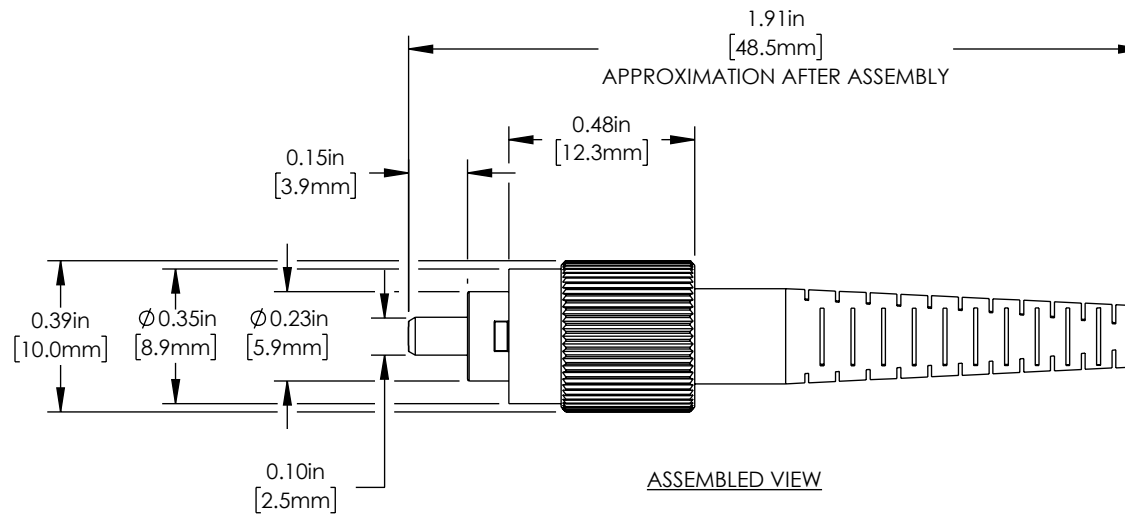

INCLUDED BUT NOT SHOWN  
• PROTECTIVE DUST CAP

FOR INFORMATION ONLY  
NOT FOR MANUFACTURING PURPOSES

DRAWING PROJECTION



	NAME	DATE
DRAWN	IR	29/JUL/17
APPROVAL	HC	07/JUN/23

COPYRIGHT © 2023 BY THORLABS

VALUES IN PARENTHESIS ARE CALCULATED  
AND MAY CONTAIN ROUND OFF ERRORS

**THORLABS**

www.thorlabs.com

MULTIMODE FC/PC CONNECTOR,  
 $\text{Ø}260\mu\text{m}$ , 3.0 mm BOOT

MATERIAL	N/A	REV B
----------	-----	-------

ITEM #	APPROX WEIGHT
30260G3	0.05 kg