

ISOMETRIC VIEW  
SCALE 1:4

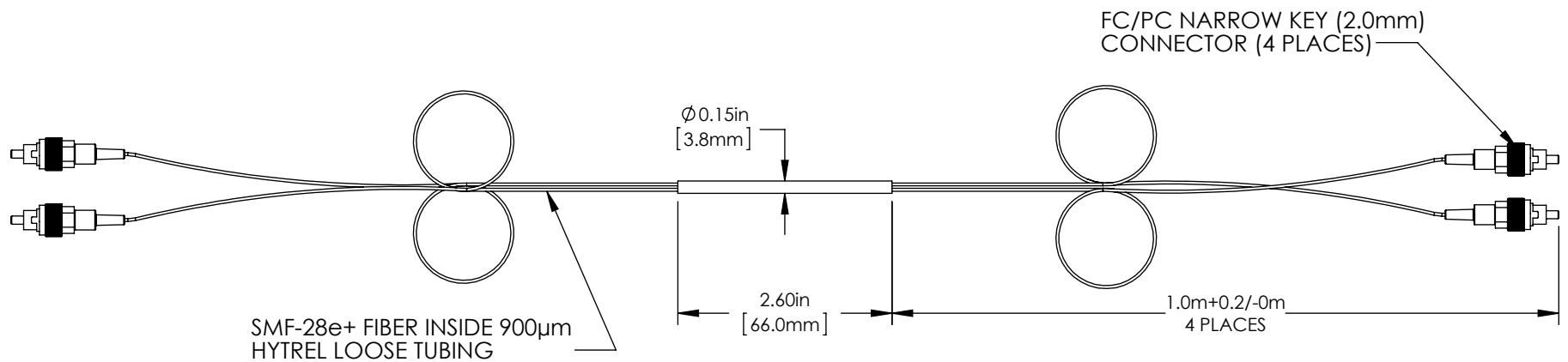

SMF-28e+ FIBER INSIDE 900µm  
HYREL LOOSE TUBING

FC/PC NARROW KEY (2.0mm)  
CONNECTOR (4 PLACES)

COUPLER SPECIFICATIONS

CENTER WAVE LENGTH	1310/1550 nm
OPERATING BAND WIDTH	±40 nm
COUPLING RATIO	99:1
INSERTION LOSS	21.6/0.4 dB
TYPICAL EXCESS LOSS	0.2 dB
PDL	<0.15 dB
DIRECTIVITY	>60 dB
OPERATING TEMPERATURE °C	-40 TO 85 °C

\* ALL SPECIFICATIONS ARE BASED ON NON-CONNECTORIZED MODEL

FOR INFORMATION ONLY  
NOT FOR MANUFACTURING PURPOSES

DRAWING PROJECTION

**THORLABS**  
www.thorlabs.com

	NAME	DATE
DRAWN	TDG	24/OCT/11
APPROVAL	KH	9/NOV/11

2X2, 1310/1550nm SM COUPLER 99:1

COPYRIGHT © 2013 BY THORLABS

MATERIAL N/A REV B

VALUES IN PARENTHESIS ARE CALCULATED AND MAY CONTAIN ROUND OFF ERRORS

ITEM # 10202A-99-FC APPROX WEIGHT 0.11 kg