

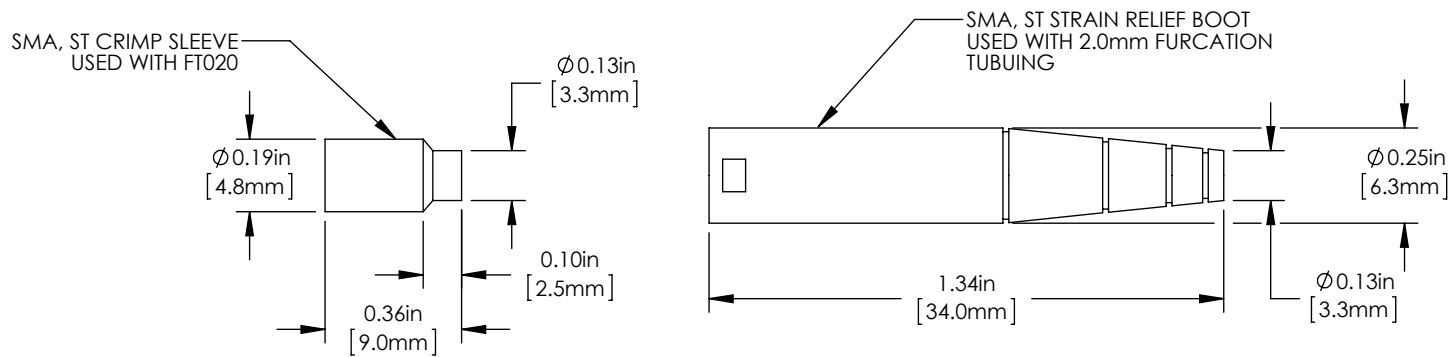

ISOMETRIC VIEW  
SCALE 2:1



**MATERIAL NOTE**

- BOOT: SANTOPRENE 251-80
- CRIMP SLEEVE: ALUMINUM ALLOY

FOR INFORMATION ONLY  
NOT FOR MANUFACTURING PURPOSES

DRAWING PROJECTION

	NAME	DATE
DRAWN	KBC	01/MAR/12
APPROVAL	BAG	11/MAY/16

**COPYRIGHT © 2016 BY THORLABS**

VALUES IN PARENTHESIS ARE CALCULATED AND MAY CONTAIN ROUND OFF ERRORS

**THORLABS**  
www.thorlabs.com

SMA, ST CRIMP SLEEVE AND BOOT, 25 PACK

MATERIAL	SEE NOTE	REV C
ITEM #	190088CP	APPROX WEIGHT 0.68g